

Cleaning- pressure cup gun 3300 DPF

Art. no.: 33140, 33158



Thank you very much for the trust you have placed in us and our products..



Please read the operating manual first before using the pressure cup gun.

This operating and maintenance manual contains important information required for the safe and trouble-free operation of your pressure cup gun. Therefore, always keep this operating manual with the pressure cup gun.

General notice:

This pressure cup gun was developed for certain applications. We explicitly point out that this pressure cup gun must not be modified and/or used in a way that does not correspond to its intended use.

Content:

1. Technical data	3
2. Extent of delivery	3
3. Intended use	3
4. Features	3
5. Safety instructions	3
6. Installation / end of work	5
7. Maintenance and care	5
8. Storage	6
9. Troubleshooting	6
10. Warranty terms	7
11. Address	7
12. EC-declaration of conformit	8
13. Notices	9
14. Technical drawing	10
15. Spare parts list	11

1. Technical data

Description	3300 DPF
Operating pressure	2-8 bar
Maximum pressure	8 bar
Container volume	1.250 ml
Connection thread Air	¼"
Compressed air supply	via quick coupling
Adjustable spray pattern	Material flow adjustable
Measurement	329 x 164 x 93 mm
Measurement cardboard	360 x 230 x 110 mm
Net weight	approx. 855 g
Gross weight	approx. 1.179 g
Weight 3900 WH 02/04	150 g *
Required air quality	filtered, condensate-free

* included with 3300 DPF-Set

2. Extent of delivery

Pressure cup gun, compressed air connection, operating manual
 Additionally included with 3300 DPF set: Hose set 3900 WH 02/04

3. Intended use

This pressure cup gun is a compressed air operated quality tool for professional use. It is suitable for processing liquid media in the form of loose containers.

4. Features

The effectiveness of the 3300 DPF pressure cup gun is based on overpressure. For this purpose, pressure is built up in the pressure container by means of an air duct integrated in the gun body. This conveys the material present in the pressure container via a riser pipe to the material nozzle. When the lever is pressed, the material flows out of the material nozzle where it is mixed with the spray air.

5. Safety instructions



This pressure cup gun is not suitable for alkaline and acidic media.

Such media must not be processed with this pressure cup gun!!!

Protect yourself and the environment by taking appropriate precautions against the risk of accidents and observe the following instructions in your own interest:



- The operator must ensure proper operation.
- Do not bring compressed air and/or medium into contact with skin or eyes.
- Never direct the spray jet at animals, people or yourself.
- Keep children and pets away from the operating area.
- No manipulations, emergency repairs or misappropriations may be carried out on the pressure cup gun.
- Pressure cup guns may only be operated and maintained by instructed persons.
- Repairs must only be carried out by qualified persons.

The following applies to all maintenance and repair work:



- It is essential to disconnect the pressure cup gun from the compressed air connection before carrying out maintenance or repair work.
- Only use original spare parts.
- The maximum working pressure must not be exceeded (see point 1 "Technical data"). The working pressure must be adjusted via a (filter) pressure reducer.
- Only use compressed air as energy source.
- The compressed air connection may only be made via quick coupling.
- When working with the pressure cup gun, wear the necessary protective clothing, protective goggles, work gloves, ear protection if necessary and a respirator mask.
- If there are leaks in the device or other operating faults, the device must be disconnected from the compressed air supply immediately and the cause of the fault must be eliminated.
- Open fire, sparks or smoking is prohibited.
- Beware of flammable materials.
- Processed media and cleaning media must be disposed of in an environmentally friendly manner.
- The disposal of the compressed air device must be carried out according to the valid legal regulations.

6. Installation / end of work

Preparing the gun for the first start-up: Screw in the compressed air connection and tighten it firmly with a 13 mm open-end or ring spanner, if necessary glue it in place.

With optional pressure regulator instead of air volume regulation: Screw the pressure gauge included in the extent of delivery into the pressure regulator, if necessary glue it in place.

Start up: Unscrew the pressure container and fill the medium into the container. Then hand-tighten the gun with the container cover onto the pressure container. Do not use any tools for this! Plug the connection nipple of the hose (type 3900 or 3901) onto the quick coupling and let it engage. Connect the gun to the compressed air supply via the quick coupling of the air connection. By pressing the trigger you put the pressure cup gun into operation.



Attention:

Wear heat-resistant gloves when using heated medium. Danger of burns!

The spray pattern can be influenced by the following factors:

- Material quantity via stop screw/nozzle needle
- Adjusting the intake pressure (optional)
- Distance between hand spray nozzle and object
- Angular position of the hand spray nozzle to the object

End of work: **Vent the pressure container by turning the pressure container counterclockwise.** Disconnect the device from the compressed air supply after each use. Empty the pressure container. Clean the device according to the instructions given in point 7.



Attention:

Never operate the trigger while the container is under pressure but the pressure cup gun is not connected to the compressed air source. This can push the medium into the air ducts and render the pressure cup gun unusable!

7. Maintenance and care

Clean the compressed air device after each use. Empty the pressure container and blow out the pressure cup gun and the hoses by putting the device into operation. If you want to clean the pressure cup gun with cleaning medium, we recommend benzine or commercially available turpentine-based cleaning medium. **Do not use aggressive cleaners!** Following the maintenance instructions will ensure a long service life and trouble-free operation for this quality product.

**Attention:**

Pay attention to a proper disposal of the residues, which arise during the maintenance and care.

8. Storage

The compressed air tool must be stored under the following conditions:

- If residual material is present, the pressure container must be emptied.
- Carefully clean the pressure cup gun after each use.
- Store in a dry and dust-free place.
- Do not expose to liquids and/or aggressive chemicals.
- Keep out of the reach of children.

9. Troubleshooting

In the event of any malfunctions, please first check whether sufficient compressed air is available and whether the spray material can still be processed.

- **Gun sprays messy**
Possible cause: Operating pressure too low, nozzles are dirty.
Solution: Increase operating pressure, clean nozzles.
- **Gun does not spray any material**
Possible cause: Riser pipe and/or nozzles are clogged.
Solution:Clean clogged parts.
- **Air exits the spray nozzle even though the trigger is in its initial position.**
Possible cause:: Valve bolt is jammed.
Solution: Pour oil onto the valve bolt and/or into the compressed air intake. Operate the trigger several times.
- **Material exits the spray nozzle even though the trigger is in its initial position.**
Possible cause: Nozzle needle is jammed / dirty.
Solution: Clean the nozzle needle, apply oil to the nozzle needle and/or slightly re-duce the pressure on the nozzle needle seal using a 9mm wrench. In order to ensure error-free use, a clamping effect on the nozzle needle seal must remain. Press the trigger several time.

10. Warranty terms

The basis for all warranty claims is the complete pressure cup gun and the proof of purchase. Damage caused by improper handling of the pressure cup gun is not covered by the warranty.

If you have any questions, please indicate the type description or the article number of the pressure cup gun.

- In conformity with legal regulations, you receive a 24-month warranty on all products against material and manufacturing defects.

Excluded from the warranty:

- Wear parts.
- Damage caused by improper use.
- Damage caused by lack of maintenance.
- Damage caused by dirt.
- Damage caused by untreated compressed air.

If warranty claims are made, the pressure cup gun must be in its original condition.

11. Address

In case of service your sales representative is at your side or contact the following address:

Vaupel GmbH
Gerätebau & Drucklufttechnik
Am Forsthaus 6
35713 Eschenburg-Simmersbach
Germany
Telephone: +49 (0) 2774 80069-0
E-Mail: info@vaupel-gmbh.de
Internet: www.vaupel-gmbh.de

Notice: We reserve the right to make technical changes. Illustrations may differ from the original. We assume no liability for printing errors.

12. EC-declaration of conformity

EC-declaration of conformity

In accordance with the EC Machine Directive 2006/42/EC ,

Type of gun: Pressure cup gun
Type designation: Type 3300 DPF
Type description: Cleaning pressure cup gun

Article number Manufacturer: 33140, 33158

Is developed, designed and manufactured in accordance with the above EC Directives, under the general responsibility of

Company: Vaupel GmbH
Gerätebau & Drucklufttechnik
Am Forsthaus 6
35713 Eschenburg-Simmersbach

The technical documentation is complete.

The following harmonised standard has been applied:

**DIN EN ISO 12100 - Sicherheit von Maschinen – Allgemeine Gestaltungsleit-
sätze - Risikobeurteilung und Risikominderung**

The operating manual belonging to the machine is available in the original version and in the respective national language.

Simmersbach, 01.04.2020

Place, Date



Signature, Managing director

13. Notices

14. Technical drawing

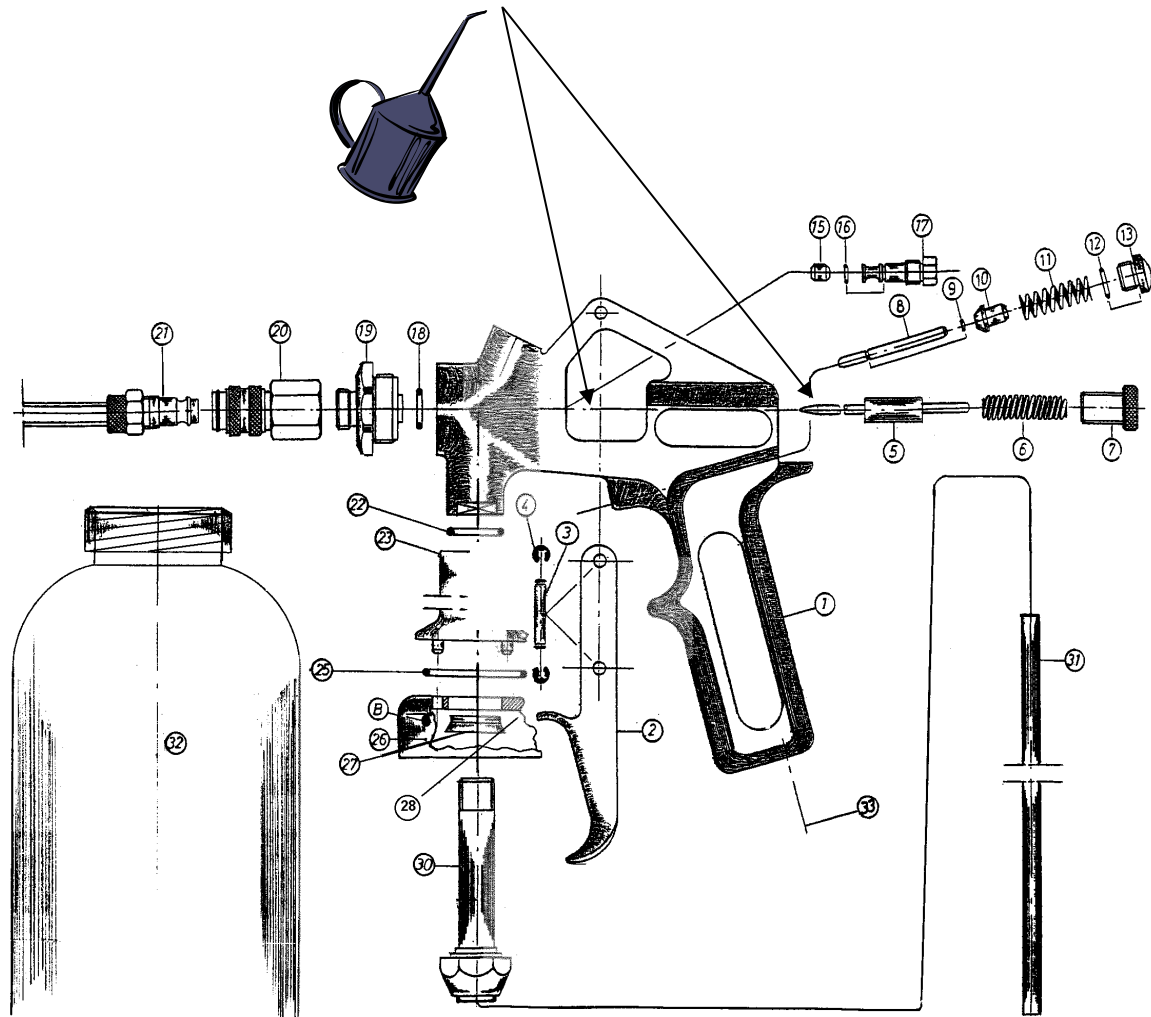

15. Spare parts list

Pos.	Article no.	Description
1		Gun body
2	50 3909 005	Trigger
3	30 1102 006	Lever axis
4	60 3100 029	Lock washer
5	83010	Nozzle needle complete
6	60 3104 007	Spring for nozzle needle
7	30 1122 005	Stop screw
8	80158	Valve bolt
9		O-ring 1.5 x 0.75 mm
10		Valve seal
11	60 3103 003	Spring for valve
12	60 4100 362	O-ring 8 x 1 mm
13	30 1120 002	Locking screw
14		
15	40 4100 003	Needle seal Teflon
16	60 4100 364	O-ring 5 x 1 mm
17	30 1421 012	Needle gland
18	60 4100 366	O-ring 8 x 2.5 mm
19	30 1422 014	Nozzle head
20	20 1413 001	Quick coupling
21	See accessories list	Cavity spray hose (accessory)
22	83313	O-ring 15 x 2 mm
23		Adapter 3000
25		O-ring 33 x 2 mm
26	10 2111 014	Cup holder
27	60 4100 344	U-cup 12 x 18 x 4.5 x 1.6
28	60 4100 387	O-ring 35 x 4 mm
29		
30	83309	Fixing screw
31	10 4102 002	Plastic riser pipe PA
32	83305	Pressure container
33	30 1423 002	Compressed air connection D
33	30 1423 001	Compressed air connection F (optional)
33	30 1413 002	Compressed air connection CH (optional)
33	30 1422 001	Compressed air connection ¼" AG (optional)